

Fingerprint Reader Access Control System

User Manual

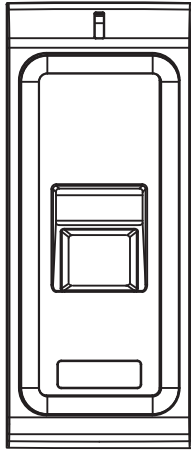

😊 Due to continuous update of our products

I. Product Overview and Installation Instruction

Applicable Models

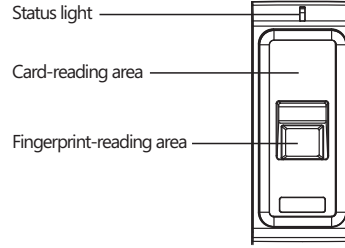

Induction area recving by Rmt Cntrl Infrared, keypad

S.N.	Functions
1	Dark-background fingerprint reader
2	User verification with fingerprint or card
3	Tamper alarm
4	Reading head for data output

- Operating Environment is as follows.
- Room temperature: -20°C-+50°C
- Relative humidity: 95%
- Operating Voltage & Current as follows.
- Input DC: +12V
- Standby current: ≤60mA
- Operating current: ≤120mA

II. Inputting Fingerprint

Suggested finger: index finger, middle finger or ring finger instead of thumb or little finger

1) Correct method

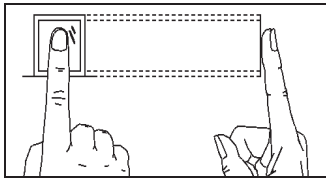

Use the finger to evenly press the center of fingerprint are

2) Wrong methods

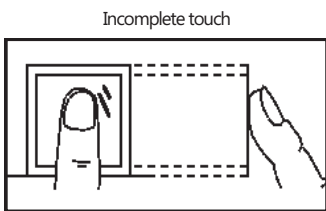

Incomplete touch

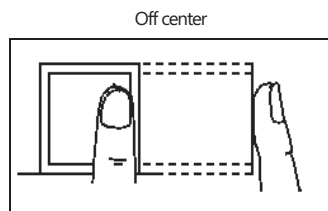

Off center

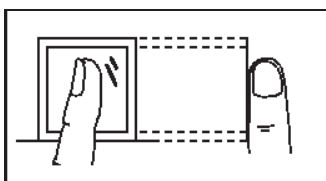

Turn sideways

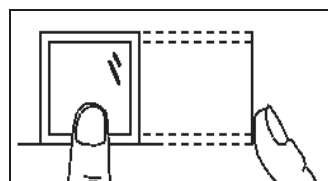

Low position

😊 Please input fingerprint correctly for verification, and improper operation might result in poor performance of this device

III. Connection power supply and lock

1. using special access control power supply wiring diagram

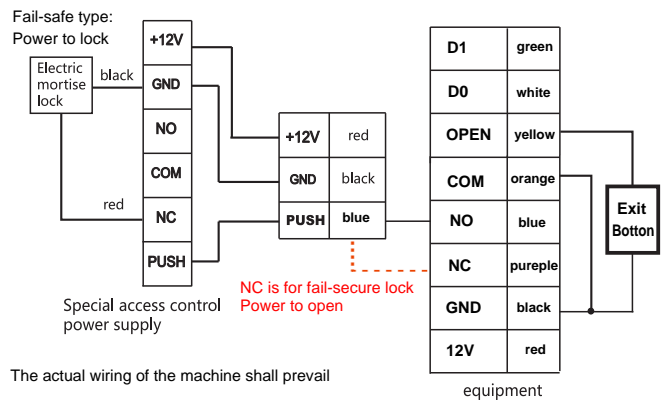

2. Using special 12V Adapter

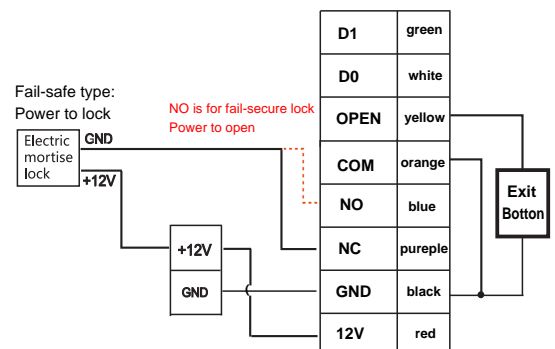

Model.FR-W1

IV. Administrator Operation

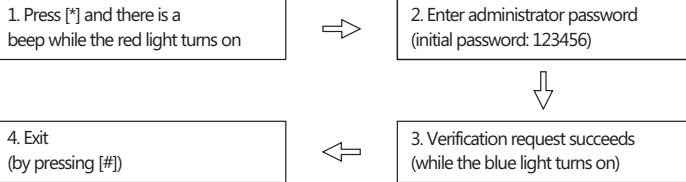

Remarks:

After successful verification, user is allowed to register Administrator account. Then the initial password will be invalid.

4.1 Registering Administrator

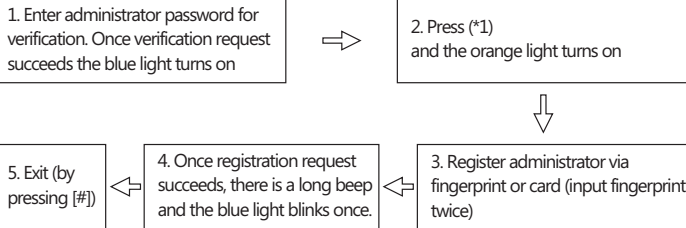

Remarks:

1. It is allowed to register with 5 administrator only via fingerprint or card.

4.2 If the administrator password is lost.

Power off, press #, hold it, and power on, after 5 seconds, there will be one long beep, means delete the master successfully, then release the button

Attention: Do not release the # button until one long beep

· 4 ·

V. To enroll a new user

5.1 A new users ID will be generated automatically.

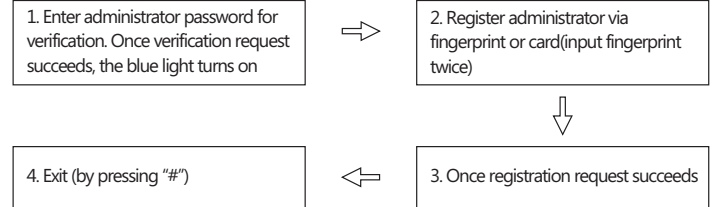

5.2 Register users by inputting the Employee ID directly.

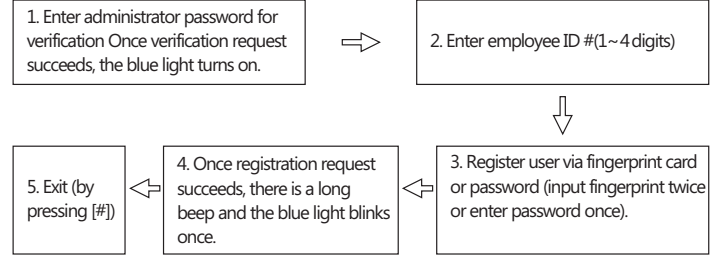

VI: Verification

6.1 User Verification via Fingerprint

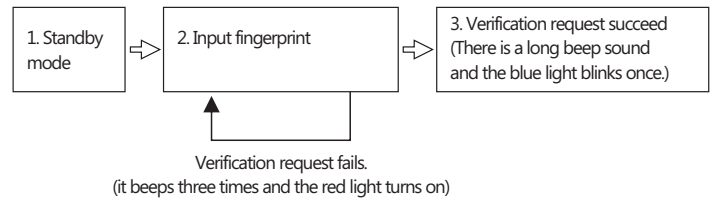

· 5 ·

6.2 User Verification via Password

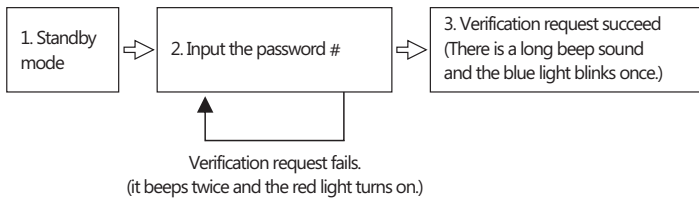

VII: Deleting Users

7.1 Delete a User

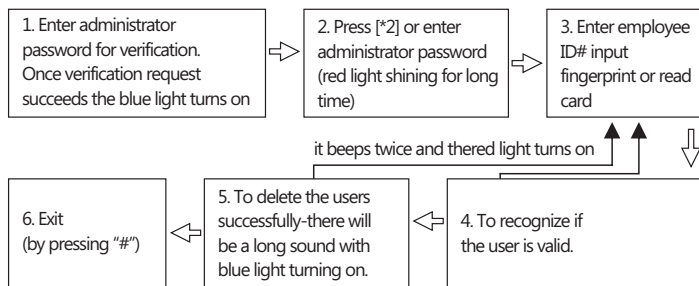

7.2 Delete All Users

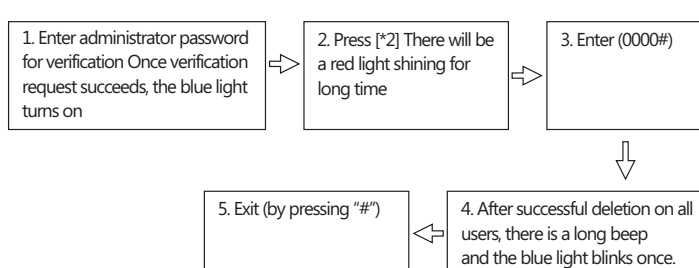

· 6 ·

VIII: Access Control System Management

8.1 System Settings

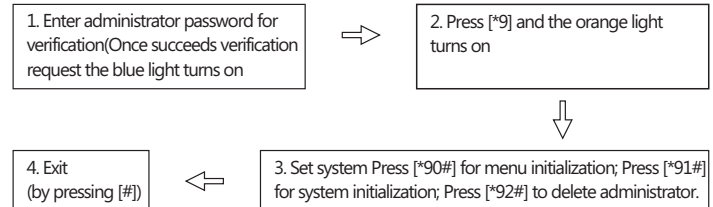

8.2 Setup the time for unlocking.

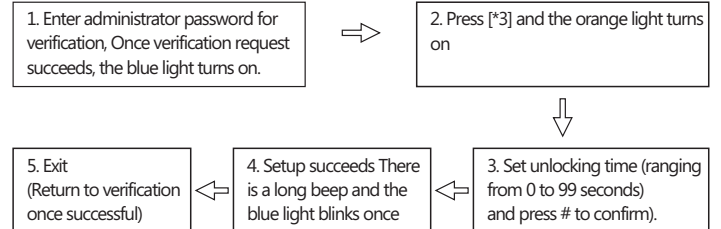

The functions for the U Disc is as follows.

To connect the U Disc,input manager fingerprint,manager card or manager password and being back to menu after successful verification.

Note: 1,The machine and U Disc will synchronize datas.

2,The user information in the machine will be updated by U Disc.

IX: Unpacking

Description	Specifications	Quantity	Remarks
Device		1	
Packaging box		1	
Plastic plugs	Φ 4mmX28mm	2	For mounting and fixing
Self-tapping screws	Φ 4mmX28mm	2	For mounting and fixing

· 7 ·